

WFL-LTFS-4 LEGAL FOR TRADE



WFL-LTFS-4 LEGAL FOR TRADE

Here's **5 COMPELLING REASONS** to choose our **LTFS**

1. The system is pre-calibrated, saving you hours of costly setup.
2. Unlike competitive systems, our LTFS does not down-rate truck capacity.
3. Click on the system forks and you are operational. No Costly Installs!
4. Economical modular components.
5. Serviceable by your local scale company.



WFL-LTFS-4 LEGAL FOR TRADE



ACCURATE

When numbers count, the LTFS provides 99.9% accuracy, fully compliant with all legal for trade applications. Accompanied by state-of-the-art electronics, the system is fully compatible with all ITA Class II, Class III and Class IV cleat type forklift trucks. Materials can be placed anywhere on the forks without affecting accuracy, so whether you're billing a shipment by weight or receiving valuable inventory, the LTFS tells you exactly what's on your forks.



EFFICIENT

Instant installation has you operational in minutes. Our systems are supplied in kit form with everything you need to quickly fit your lift truck, including step-by-step instructions. The LTFS has been specially designed for quick and easy service by your local scale technician. Adaptable for piece counting, removable for service or maintenance, and with no alterations necessary, it also makes a perfect companion for rented or leased lift trucks.



DURABLE

With other scales being problematic and expensive to service, our LTFS offers you long-term usage without the need for calibration. This exceptional scale is designed for punishing cross-docking operations, and is the first choice for shipping/receiving or harsh production environments. With no moving parts or electromechanical devices to adjust, this patent pending design is elegantly simple with minimal part wear.



AFFORDABLE

Invest in your organization's profit. Weigh Point has always determined to offer unique and affordable solutions designed to save you money, while allowing you to maximize revenue at the same time. The LTFS is not only a fraction of the up-front price of other lift truck scales, but because of its simple and durable construction is an economical choice for the long haul.



FEATURES:

- Accurate from 5 lbs to full capacity of 4400 lbs.
- Overload alert safety feature can control maximum load limits.
- Protects lift truck safety: No false carriage to increase the 24" load center or reduce capacity by up to 800 lbs.
- Accumulate, count, auto zero and tare features.
- Full connect-ability to computers and printers.
- Made in Canada.

Case Studies

Transportation

Costly scale breakdowns and unreliability were factors discouraging a southern Ontario transport company, when initially approached with our forklift truck scale offer.

The company had a legal for trade floor scale for cross-docking, which to the displeasure of management was seldom utilized, resulting in a loss of revenue due to inaccurate waybill weights.

Further analysis showed that management and dock personnel were struggling to harmonize company directives. Administration was focused on bottom line profit, optimizing freight billing by correcting understated weights, whereas dock personnel were under time constraints to load trailers expediently. Any extra steps, such as re-scaling on their floor scale, would severely delay the cross-docking operations. The company had experience with forklift scales, but the legal for trade units available left them with major reservations.

- Cost: upwards of \$11,000.00 a unit
- False carriage design down-rated the lift truck capacity by 400-800 lbs
- Frequent & costly service requirements
- Most service companies reluctant or unable to service due to proprietary design or complexity to calibrate

Weigh Point was familiar with these all too common failings, and assured the company that their innovative lift truck scale design would meet both management and warehouse needs as well as budget requirements.

Weigh Point's LTFS model was temporarily installed on a lift truck (a 5 minute procedure) and because it came pre-calibrated, the company was able to run trials immediately. The result was a resounding success for the transport company, allowing them to efficiently meet company objectives.

When NUMBERS Count

Small weight increments ensure accurate results every time.



Meat Packing

Specialty cuts of veal and lamb to upscale restaurants was the proverbial backbone of a Toronto area meat packer. This central Ontario business was actively looking to lower costs, so as to provide the restaurateurs the very best value in a highly competitive and price sensitive market.

The packing staff were fully aware of the importance of tracking inventory, preventing shrinkage losses and controlling received meats by comparing bill of lading or manifest weights against the actual invoice. Unfortunately, to provide such scrutiny was simply taking too much time and costing too much in labour.

When presented with the challenge, Weigh point suggested their Legal-for-Trade Certified Forklift Scale, that would confirm carcass weights with ultra accuracy, without double handling. The non-certified hand pallet truck and electric walkie scales were also great one step aids in weighing production portions, especially for mixing ground meat ingredients.

Weigh Point's mobile weighing solutions enabled the meat packers to supply their clients with the high quality and price competitive products they were accustomed to.



DON'T leave any more **MONEY** on the **SCALE.**

Our Legal-for-Trade system is portable and pre-calibrated at the Weigh Point Factory, taking only a few minutes to install and ready system for use. Unlike competitive systems, the LTFS only slightly down rates the forklift's capacity by maintaining the standard 24" load center, safely lifting a capacity load.

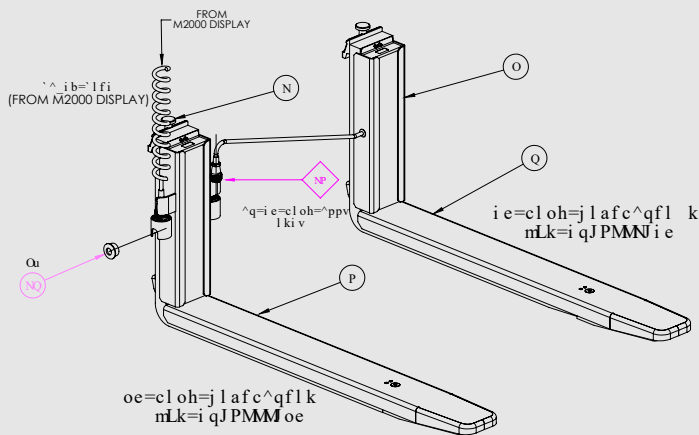

- North American and International patent pending.
- extreme overload factor of 24000 lbs for load cells
- Fully compliant with Weights & Measures.
- Final calibration and inspection required by Weights & Measures for legal for trade usage, a simple task for the LTFS system.

LTFS Specifications:

Inclinometer

- Solid state circuitry
- Detects angle deviations to a fraction of a degree
- No moving parts, uses passive switching

Trimmers

- Individual load cell trim affected by two independent trim cards

Cabling/Connectors

- Utilizes military grade, high impact connectors
- Included selection of coil cable (6' expandable to 24') or choose internal reeving kit

Sensed Forks

- 46 1/2" work face
- front taper for easy pallet entry
- sturdy construction utilizing famous manufacturer forks
- standard shear beam load cell for low cost replacement



Affordable · Effective · Unique · Easy-to-Install

Why **Weigh**Point?

Knowing the right weight instantly can make all the difference between profit and loss. As a leader in industrial-strength weighing systems, Weigh Point manufactures innovative solutions tailored to fit your industry and application.

Most importantly, our solutions are designed to be easy-to-install, affordable to own, and downright built tough, meaning less maintenance than the other guys. We Invent and Develop all of our unique scales to be dynamic solutions based around top industry concerns. Fully confident, we then back them up with a 1 year warranty and exceptional customer service, eliminating the headaches of problematic scales.

With weighing and counting solutions from a few milligrams to a million pounds, Weigh Point has been helping our customers find the right scale for each application for over 30 years.

Stationary Scales

With 99% and better accuracy, our stationary scales are the most flexible systems available, ranging from ultra-sensitive milligram scales to platform scales able to accurately weigh up to 100,000 lbs. Every scale also features our amazingly easy-to-use weight computer. Call us anytime for information on our affordable, custom application solutions.



Automation Solutions

Designed for high-speed manufacturing and robotic systems, our load cell solutions have no moving parts and are accurate to 99.5%. Our automation solutions also offer either a PLC compatible signal, or an all-digital programmable microprocessor module ready to interface to any computer.



Lift Trucks

Imagine accurately weighing pallets right on the lift truck. Choose from three incredibly easy-to-install systems that let operators weigh pallets with accuracies up to 99.9%. Our systems are supplied in kit form with everything you need to quickly outfit your lift truck.



Electric Walkies

Transform your electric walkies and riders into profit centers. We offer a range of affordable solutions that turn your pallet trucks into incredibly accurate weighing machines. With accuracy of 99%, your electric pallet trucks can now do more than just move inventory.



Front-End Loaders

Knowing the right weight means knowing the right quantity. Our front-end loader weigh scale kits are quick and easy-to-install and built tough to last. In fact, installation can be done in a matter of an hour, meaning minimal downtime. And with in-cab digital displays, operators are provided with accurate weights instantly.



Loadcell Products

Without moving parts, load cells are one of the most innovative, accurate, rugged and easy-to-install weighing solutions available. Weigh Point provides components to complete weighing kits for almost every possible application. It's no surprise, we even design and build affordable custom load cell solutions.

